

# CAPRI 3V EcoDesign

# PANADERO

## MAßE

MAßE H x B x T	695x640x393 mm
GEWICHT BRUTTO/NETTO	103/93 kg
MAßE FEUERRAUMTÜR	465x260 mm
DURCHMESSER DES ABGASSTUTZEN	Ø 150-153 mm Vertical

## EIGENSCHAFTEN

RÜTTELROST AUS GUSSEISEN	
DREISEITIGE FEUERSICHT	
BLECHGEHÄUSE	4 mm
NENNLEISTUNG	5,9 KW
WIRKUNGSGRAD	77 %
CO - EMISSIONEN	0,10 %
HITZSCHUTZANSTRICH	800°C
GLASKERAMIKSCHEIBE HITZEBESTÄNDIG BIS	750°C

EAN 8426964184556  
REF. PANADERO 18455

## PRODUKT PLUS

### ECODESIGN 2022



**EXTERNE  
LUFTZUFUHR**



**VERMIKULIT  
AUSKLEIDUNG**



**SCHEITLÄNGE 50 CM**



**RAUMHEIZVERMÖGEN**



**SCHEIBENSPÜLUNG**



**DREIFACHVERBRENNUNG**



**BEDRUCKTE  
GLASKERAMIK**

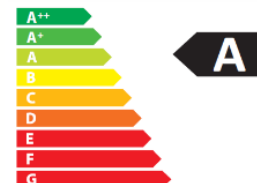
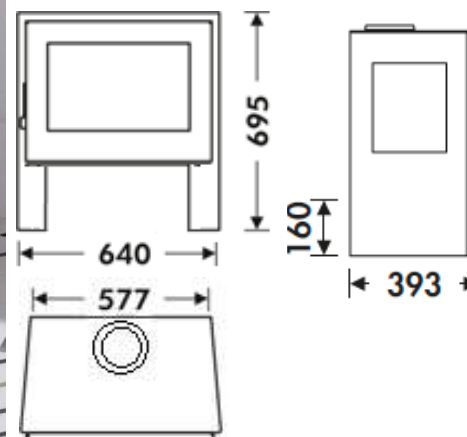

Art. 15a B-VG

**BImSchV2**



*flamme*  
**VERTE**

Le label  
du chauffage  
au bois

**7 ★**



CAPRI